



LCD MODULE SPECIFICATION FOR APPROVAL	DATE	31/05/05
	VER.	1.1
JHD529M1	PAGE	1

CUSTOMER:

P/N: JHD529M1

CUSTOMER APPROVAL

CHECKED	CHECKED	APPROVAL

SUPPLIER APPROVAL

CHECKED	CHECKED	APPROVAL

Tel : 86-755-84867757

Fax : 86-755-84802441

Address : Room A512, Baohua office building,
Shenzhen, P.R.China

E-mail: willar@tom.com

Website: www.willar.com



LCD MODULE SPECIFICATION FOR APPROVAL	DATE	31/05/05
	VER.	1.1
JHD529M1	PAGE	3

CONTENTS

1.	FEATURES	4
2.	MECHANICAL SPEC	4
3.	ABSOLUTE MAXIMUM RATING	5
4.	ELECTRICAL CHARACTERISTICS	5
5.	ELECTRO-OPTICAL CHARACTERISTICS	6
6.	QC/QA PROCEDURE	7
7.	RELIABILITY	8
8.	BLOCK DIAGRAM	9
9.	POWER SUPPLY	9
10.	TIMIING DIAGRAM	10
11.	AC CHARACTERISTICS.....	11
12.	INSTRUCTION SET	12
13.	HANDLING PRECAUTION.....	14
14.	EXTERNAL DIMENSION	17
15.	INTERFACE	18



LCD MODULE SPECIFICATION FOR APPROVAL	DATE	31/05/05
	VER.	1.1
JHD529M1	PAGE	4

1. FEATURES

- Display construction..... 128*64 DOTS
- Display mode STN / Yellow Green
- Display type Positive Transmissive
- Viewing direction..... 6 o'clock
- Operating temperature..... Indoor
- Driving voltage..... Single power
- Driving method..... 1/33 duty, 1/6bias
- Type..... COB (Chip On Board)
- Number of data line..... 8-bit parallel
- Connector..... Pin

2. MECHANICAL DATA

ITEM		WIDTH	HEIGHT	THICKNESS	UNIT
Module size		93.0	70.0	12.7(MAX)	mm
Viewing area		70.7	38.8	-	mm
Dot	Size	0.48	0.48	-	mm
	Pitch	0.52	0.52	-	mm
Diameter of mounting hole		2.7			mm
Weight		About 50			g



LCD MODULE SPECIFICATION FOR APPROVAL	DATE	31/05/05
	VER.	1.1
JHD529M1	PAGE	5

3. ABSOLUTE MAXIMUM RATINGS

Characteristics	Symbol	Value
Power Supply Voltage	V_{DD}	-0.3V to +5.5V
LCD Driver Voltage	V_{LCD}	-0.3V to +7.0V
Input Voltage	V_{IN}	-0.3V to $V_{DD}+0.3V$
Operating Temperature	T_A	-20°C to +85°C
Storage Temperature	T_{STO}	-55°C to +125°C

4. ELECTRICAL CHARACTERISTICS

Symbol	Characteristics	Test Condition	Min.	Typ.	Max.	Unit
V_{DD}	Operating Voltage	-	2.7	-	5.5	V
V_{LCD}	LCD Voltage	V_0-V_{SS}	3.0	-	7	V
I_{CC}	Power Supply Current	$f_{OSC} = 530KHz, V_{DD}=3.0V$ $R_f=18K\Omega$	-	0.20	0.45	mA
V_{IH1}	Input High Voltage (Except OSC1)	-	$0.7V_{DD}$	-	V_{DD}	V
V_{IL1}	Input Low Voltage (Except OSC1)	-	-0.3	-	0.6	V
V_{IH2}	Input High Voltage (OSC1)	-	$V_{DD} - 1$	-	V_{DD}	V
V_{IL2}	Input Low Voltage (OSC1)	-	-	-	1.0	V
V_{OH1}	Output High Voltage (DB0 - DB7)	$I_{OH} = -0.1mA$	$0.8V_{DD}$	-	V_{DD}	V
V_{OL1}	Output Low Voltage (DB0 - DB7)	$I_{OL} = 0.1mA$	-	-	0.1	V
V_{OH2}	Output High Voltage (Except DB0 - DB7)	$I_{OH} = -0.04mA$	$0.8V_{DD}$	-	V_{DD}	V
V_{OL2}	Output Low Voltage (Except DB0 - DB7)	$I_{OL} = 0.04mA$	-	-	$0.1V_{DD}$	V
I_{LEAK}	Input Leakage Current	$V_{IN} = 0V$ to V_{DD}	-1	-	1	μA
I_{PUP}	Pull Up MOS Current	$V_{DD} = 3V$	22	27	32	μA

LCD MODULE SPECIFICATION FOR APPROVAL	DATE	31/05/05
	VER.	1.1
JHD529M1	PAGE	6

5. ELECTRO-OPTICAL CHARACTERISTICS

ITEM	SYMBOL	CONDITION	MIN.	TYP.	MAX.	UNIT	NOTE
Contrast ratio	K	$\varphi=0$	1.4	4	-	-	1
Response time (rise)	Tr	$\varphi=0$	-	250	300	ms	2
Response time (fall)	Tf	$\varphi=0$	-	250	350	ms	2
Viewing angle	φ	K ≥ 2.0	-40 -- +40			deg.	3
	θ		-30 -- +30				

Note 1: Definition of Contrast Ratio "K"

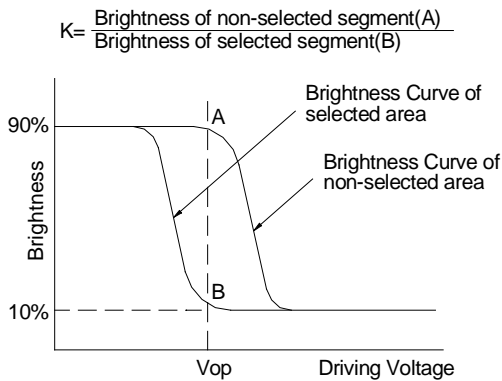

Note 2: Definition of Optical Response Time

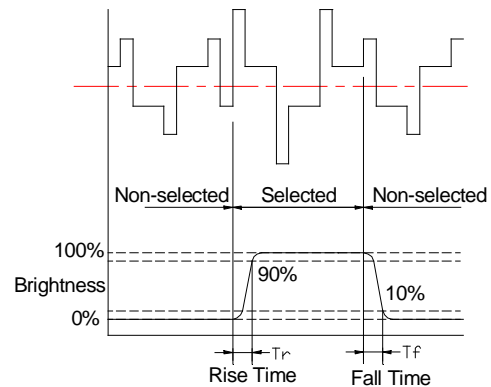

Note 3: Definition of Viewing Angle

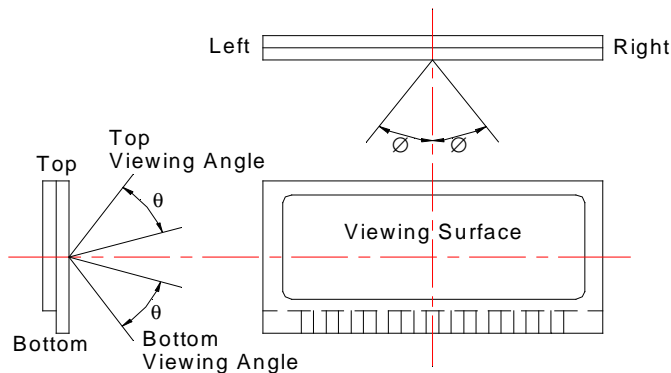

Please select either top or bottom viewing angle



LCD MODULE SPECIFICATION FOR APPROVAL	DATE	31/05/05
	VER.	1.1
JHD529M1	PAGE	7

6. QC/QA PROCEDURE

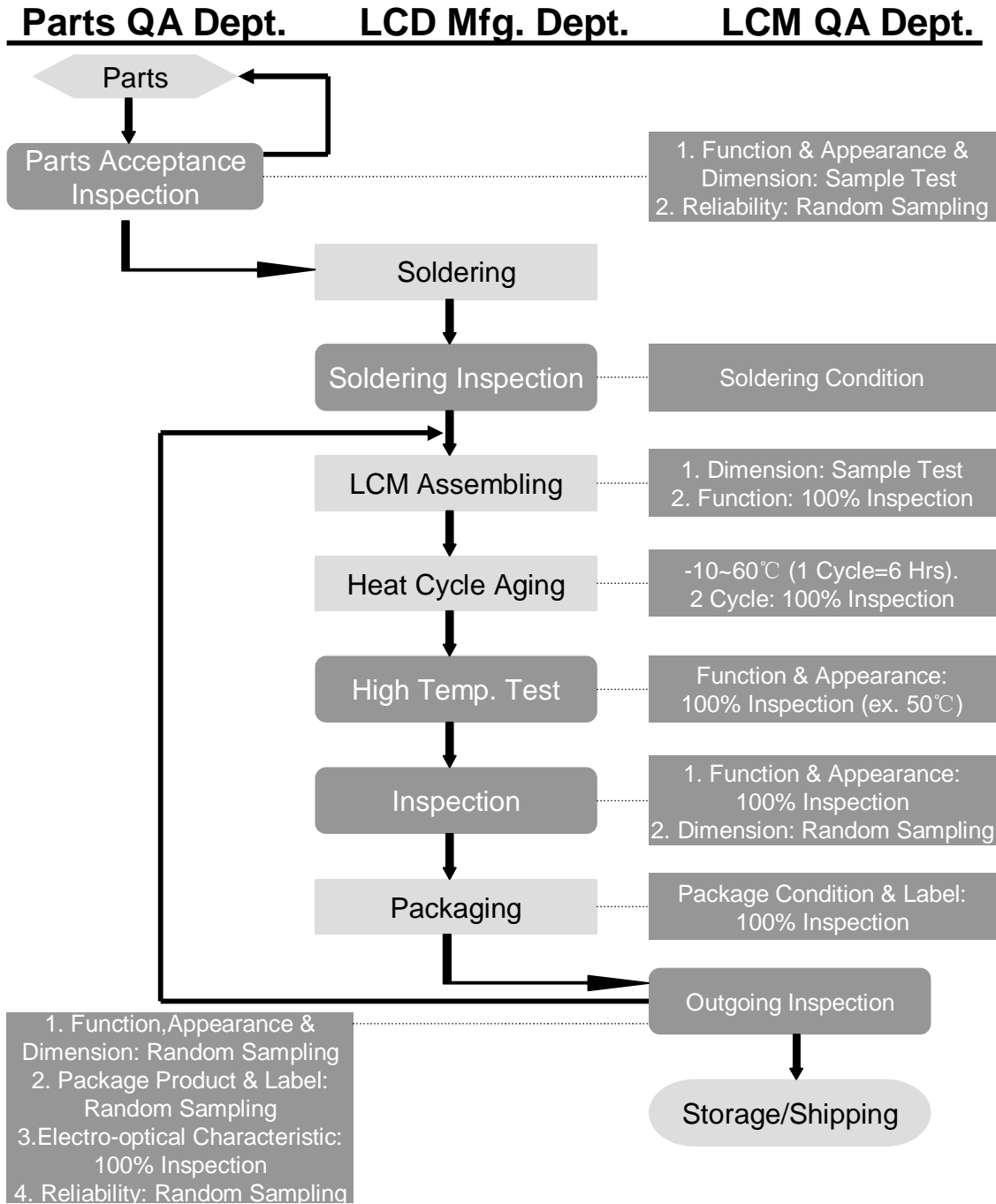



LCD MODULE SPECIFICATION FOR APPROVAL	DATE	31/05/05
	VER.	1.1
JHD529M1	PAGE	8

7. RELIABILITY

- Operating life time:

Longer than 50000 hours (at room temperature without direct irradiation of sunlight)

- Reliability Characteristics:

Item	Test	Criterion
High temp	60°C / 200 Hrs	n Total current consumption should be below double of initial value n Contrast ratio should be within initial value±50% n No defect in cosmetic and operational function is allowable
Low temp.	-10°C / 200 Hrs	
High humidity	40°C * 90%RH / 200 Hrs	
Thermal shock	-10°C→25°C→60°C→25°C /5 Cycles (30min) (5min) (30min) (5min)	
Vibration	1.Operating time: Thirty minutes exposure in each direction (x, y, z) 2.Sweep Frequency (1min):10Hz→ 55Hz→10Hz 3.Amplitude: 0.75mm double amplitude	

LCD MODULE SPECIFICATION FOR APPROVAL	DATE	31/05/05
	VER.	1.1
JHD529M1	PAGE	9

8. BLOCK DIAGRAM & 9. POWER SUPPLY

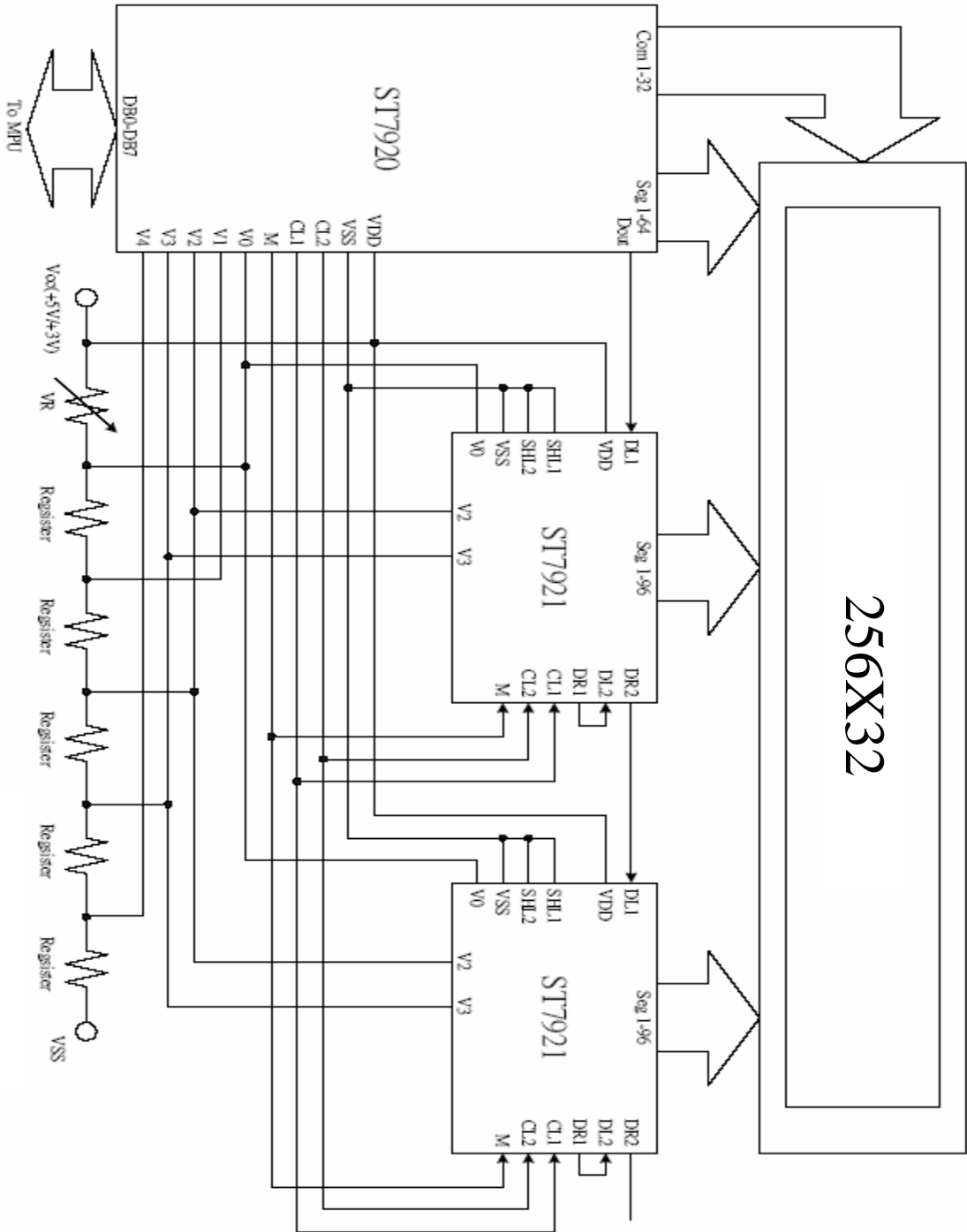

LCD MODULE SPECIFICATION FOR APPROVAL	DATE	31/05/05
	VER.	1.1
JHD529M1	PAGE	10

10. TIMING DIAGRAM

- MPU write data to ST7920

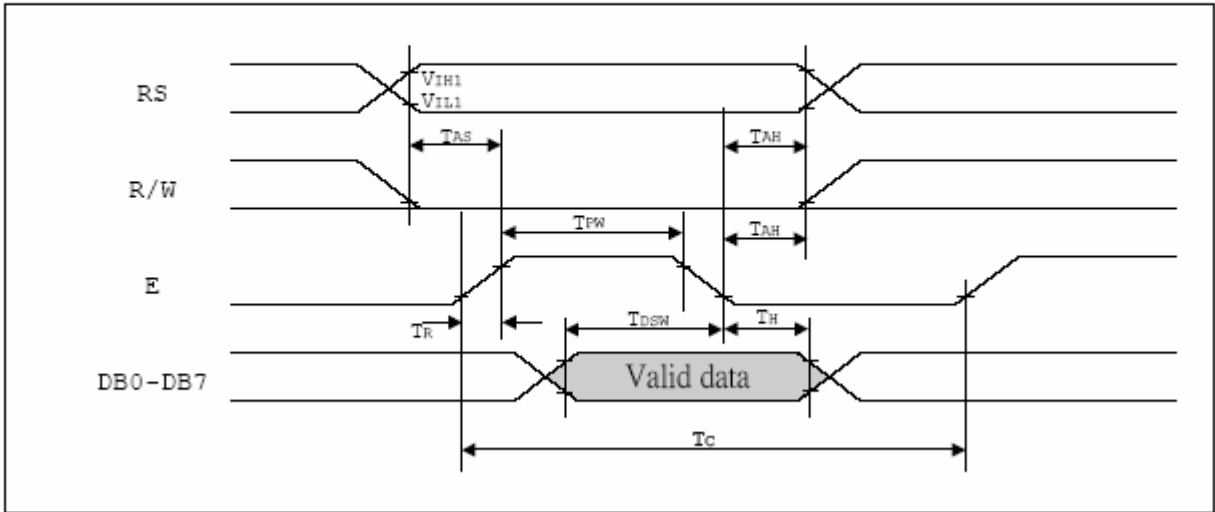

- MPU read data from ST7920

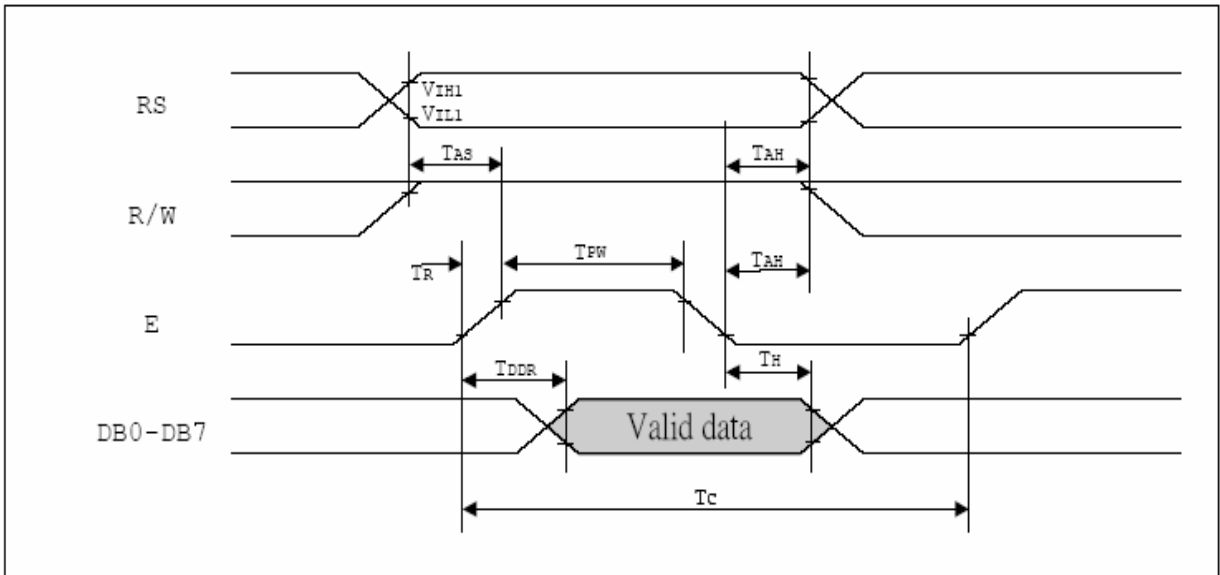



LCD MODULE SPECIFICATION FOR APPROVAL	DATE	31/05/05
	VER.	1.1
JHD529M1	PAGE	11

11. AC CHARACTERISTICS

AC Characteristics ($T_A = 25^\circ\text{C}$, $V_{DD} = 4.5\text{V}$) Parallel Mode Interface

Symbol	Characteristics	Test Condition	Min.	Typ.	Max.	Unit
<i>Internal Clock Operation</i>						
f_{OSC}	OSC Frequency	R = 33K Ω	480	540	600	KHz
<i>External Clock Operation</i>						
f_{EX}	External Frequency	-	480	540	600	KHz
	Duty Cycle	-	45	50	55	%
T_R, T_F	Rise/Fall Time	-	-	-	0.2	μs
<i>Write Mode (Writing data from MPU to ST7920)</i>						
T_C	Enable Cycle Time	Pin E	1200	-	-	ns
T_{PW}	Enable Pulse Width	Pin E	140	-	-	ns
T_R, T_F	Enable Rise/Fall Time	Pin E	-	-	25	ns
T_{AS}	Address Setup Time	Pins: RS,RW,E	10	-	-	ns
T_{AH}	Address Hold Time	Pins: RS,RW,E	20	-	-	ns
T_{DSW}	Data Setup Time	Pins: DB0 - DB7	40	-	-	ns
T_H	Data Hold Time	Pins: DB0 - DB7	20	-	-	ns
<i>Read Mode (Reading Data from ST7920 to MPU)</i>						
T_C	Enable Cycle Time	Pin E	1200	-	-	ns
T_{PW}	Enable Pulse Width	Pin E	140	-	-	ns
T_R, T_F	Enable Rise/Fall Time	Pin E	-	-	25	ns
T_{AS}	Address Setup Time	Pins: RS,RW,E	10	-	-	ns
T_{AH}	Address Hold Time	Pins: RS,RW,E	20	-	-	ns
T_{DDR}	Data Delay Time	Pins: DB0 - DB7	-	-	100	ns
T_H	Data Hold Time	Pins: DB0 - DB7	20	-	-	ns
<i>Interface Mode with LCD Driver(ST7921)</i>						
T_{CWH}	Clock Pulse with High	Pins: CL1, CL2	800	-	-	ns
T_{CWL}	Clock Pulse with Low	Pins: CL1, CL2	800	-	-	ns
T_{CST}	Clock Setup Time	Pins: CL1, CL2	500	-	-	ns
T_{SU}	Data Setup Time	Pin: D	300	-	-	ns
T_{DH}	Data Hold Time	Pin: D	300	-	-	ns
T_{DM}	M Delay Time	Pin: M	-1000	-	1000	ns



LCD MODULE SPECIFICATION FOR APPROVAL	DATE	31/05/05
	VER.	1.1
JHD529M1	PAGE	12

12. INSTRUCTION SET

Instruction set 1: (RE=0: basic instruction)

Ins	code										Description	Exec time (540KHZ)
	RS	RW	DB7	DB6	DB5	DB4	DB3	DB2	DB1	DB0		
CLEAR	0	0	0	0	0	0	0	0	0	1	Fill DDRAM with "20H", and set DDRAM address counter (AC) to "00H"	1.6 ms
HOME	0	0	0	0	0	0	0	0	0	1 X	Set DDRAM address counter (AC) to "00H", and put cursor to origin ; the content of DDRAM are not changed	72us
ENTRY MODE	0	0	0	0	0	0	0	0	1	ID S	Set cursor position and display shift when doing write or read operation	72us
DISPLAY ON/OFF	0	0	0	0	0	0	0	1	D	C B	D=1: display ON C=1: cursor ON B=1: blink ON	72 us
CURSOR DISPLAY CONTROL	0	0	0	0	0	1	S/C	R/L	X	X	Cursor position and display shift control ; the content of DDRAM are not changed	72 us
FUNCTION SET	0	0	0	0	1	DL	X	0 RE	X	X	DL=1 8-BIT interface DL=0 4-BIT interface RE=1: extended instruction RE=0: basic instruction	72 us
SET CGRAM ADDR.	0	0	0	1	AC5	AC4	AC3	AC2	AC1	AC0	Set CGRAM address to address counter (AC) Make sure that in extended instruction SR=0 (scroll or RAM address select)	72 us
SET DDRAM ADDR.	0	0	1	0 AC6	AC5	AC4	AC3	AC2	AC1	AC0	Set DDRAM address to address counter (AC) AC6 is fixed to 0	72 us
READ BUSY FLAG (BF) & ADDR.	0	1	BF	AC6	AC5	AC4	AC3	AC2	AC1	AC0	Read busy flag (BF) for completion of internal operation, also Read out the value of address counter (AC)	0 us
WRITE RAM	1	0	D7	D6	D5	D4	D3	D2	D1	D0	Write data to internal RAM (DDRAM/CGRAM/IRAM/GDRAM)	72 us
READ RAM	1	1	D7	D6	D5	D4	D3	D2	D1	D0	Read data from internal RAM (DDRAM/CGRAM/IRAM/GDRAM)	72 us



LCD MODULE SPECIFICATION FOR APPROVAL	DATE	31/05/05
	VER.	1.1
JHD529M1	PAGE	13

Instruction set 2: (RE=1: extended instruction)

Inst.	code										description	Exec. time (540KHZ)
	RS	RW	DB7	DB6	DB5	DB4	DB3	DB2	DB1	DB0		
STAND BY	0	0	0	0	0	0	0	0	0	1	Enter stand by mode, any other instruction can terminate (Com1..32 halted, only Com33 ICON can display)	72 us
SCROLL or RAM ADDR. SELECT	0	0	0	0	0	0	0	0	1	SR	SR=1: enable vertical scroll position SR=0: enable IRAM address (<u>extended instruction</u>) SR=0: enable CGRAM address(<u>basic instruction</u>)	72 us
REVERSE	0	0	0	0	0	0	0	1	R1	R0	Select 1 out of 4 line (in DDRAM) and decide whether to reverse the display by toggling this instruction R1,R0 initial value is 00	72 us
SLEEP	0	0	0	0	0	0	1	SL	X	X	SL=1: leave sleep mode SL=0: enter sleep mode	72 us
EXTENDED FUNCTION SET	0	0	0	0	1	DL	X	1 RE	G	0	DL=1 8-BIT interface DL=0 4-BIT interface <u>RE=1: extended instruction set</u> <u>RE=0: basic instruction set</u> G=1 :graphic display ON G=0 :graphic display OFF	72 us
SET IRAM or SCROLL ADDR	0	0	0	1	AC5	AC4	AC3	AC2	AC1	AC0	SR=1: AC5~AC0 the address of vertical scroll SR=0: AC3~AC0 the address of ICON RAM	72 us
SET GRAPHIC RAM ADDR.	0	0	1	0	0	0	AC3	AC2	AC1	AC0	Set GDRAM address to address counter (AC) First set vertical address and the horizontal address by consecutive writing Vertical address range AC6...AC0 Horizontal address range AC3...AC0	72 us

LCD MODULE SPECIFICATION FOR APPROVAL	DATE	31/05/05
	VER.	1.1
JHD529M1	PAGE	14

13. Handling Precautions

1. Limitation of Application:

Optrex products are designed for use in ordinary electronic devices such as business machines, telecommunications equipment, measurement devices and etc. Please handle the products with care. (see below)

Optrex products are not designed, intended, or authorized for use in any application which the failure of the product could result in a situation where personal injury or death may occur. these applications include, but are not limited to. life-sustaining equipment, nuclear control devices, aerospace equipment, devices related to hazardous or flammable materials, etc. [If Buyer intends to purchase or use the Optrex Products for such unintended or unauthorized applications, Buyer must secure prior written consent to such use by a responsible officer of Optrex Corporation.] Should Buyer purchase or use Optrex Products for any such unintended or unauthorized application [without such consent]. Buyer shall indemnify and hold Optrex and its officers, employees, subsidiaries, affiliates and distributors harmless against all claims, costs, damages and expenses, and reasonable attorney's fees, arising out of, directly or indirectly, any claim of personal injury or death associated with such unintended or unauthorized use, even if such claim alleges that Optrex was negligent regarding the design or manufacture of the part.

2. Industrial Rights and Patents

Optrex shall not be responsible for any infringement of industrial property rights of third parties in any country arising out of the application or use of Optrex products, except which directly concern the structure or production of such products.

No Press and Shock!

If pressure to LCD, orientation may be disturbed.
LCD will broken by shock!

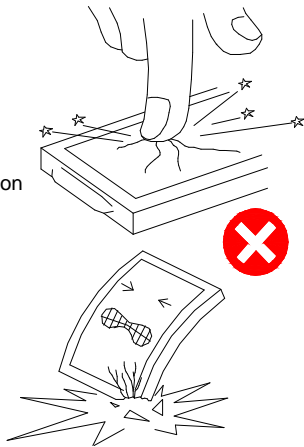

Don't Swallow or Touch Liquid Crystal!

Liquid Crystal may be leaked when display is broked.
If it accidentally gets your hands, wash then with water!

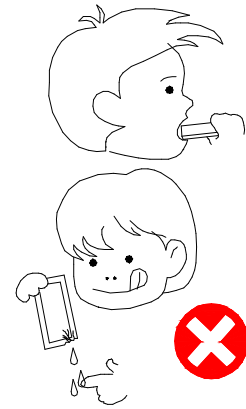

Don't not Scratch!

Polarizer is a soft material and can easily be scratched.

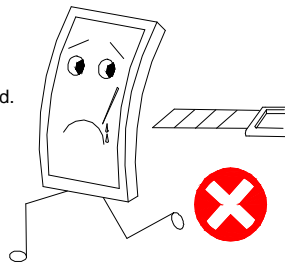

No DC Voltage to LCD!

DC voltage or driving higher than the specified voltage will reduce the lifetime of the LCD.

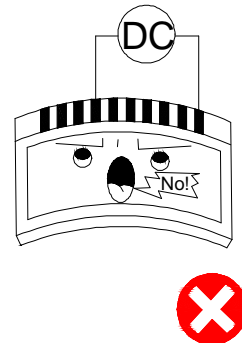

LCD MODULE SPECIFICATION FOR APPROVAL	DATE	31/05/05
	VER.	1.1
JHD529M1	PAGE	15

Don't Press the Metallic Frame and Disassemble the LCM

Pressure on the metallic frame and PCB may deform the conductive rubber or break the liquid crystal cell and back light, which will cause defects.

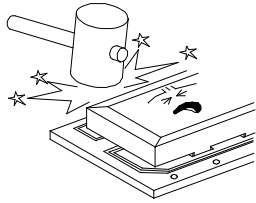

LCD may be shifted or conductive rubber may be reshaped, which will cause defects.

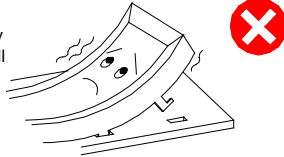

Slowly Peel Off Protective Film!

Avoid static electricity.

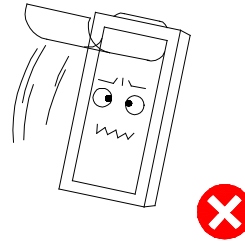

Avoid Static Electricity!

Please be sure to ground human body and electric appliances during work.

It is preferable to use conductive mat on table and wear cotton clothes or conduction processed fiber. Synthetic fiber is not recommended.

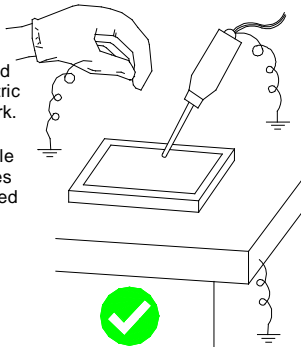

Wear Gloves While Handling!

It is preferable to wear gloves to avoid damaging the LCD.

Please do not touch electrodes with bare hands or make them dirty.

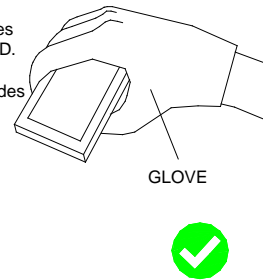

Keep Away From Extreme Heat and Humidity!

LCD deteriorates.

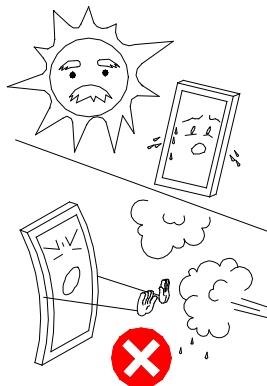

Use Alcohol to Clean Terminals!

When attaching with the heat seal or anisotropically conductive film, wipe off with alcohol before use.

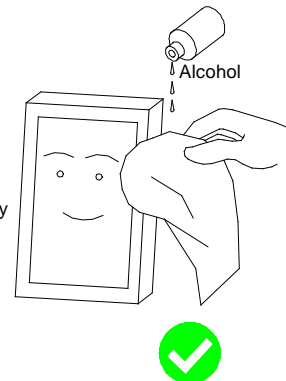

LCD MODULE SPECIFICATION FOR APPROVAL	DATE	31/05/05
	VER.	1.1
JHD529M1	PAGE	16

Don't Drop Water on LCD!

Note that the presence of waterdrops or dew in the LCD panel may deteriorate the polarizer or corrode electrode.

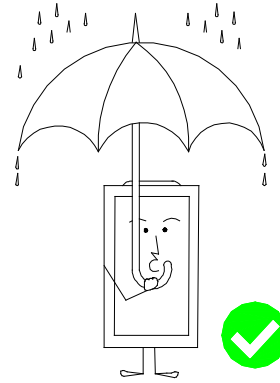

Precaution in Soldering LCD Module

Basic instructions: Solder I/O terminals only.
Use soldering iron without leakage.

(1) Soldering condition to I/O terminals

Temperature at tip of the iron: $280 \pm 10^\circ\text{C}$

Soldering time: 3~4 sec.

Type of solder: Eutectic solder (containing colophony-flux)

*Please do not use flux because it may soak into LCD Module or contaminate it.

*It is preferable to peel off protective film on display surface after soldering I/O terminals is finished.

(2) Remove connector or cable

*When you remove connector or cable soldered to I/O terminals, please confirm that solder is fully melted. If you remove by force, electrodes at I/O terminals may be damaged (or stripped off).

*It is recommended to use solder suction machine.

Long-term Storage

If it is necessary to store LCD modules for a long time, please comply with the following procedures.

If storage condition is not satisfactory, display (especially polarizer) may be deteriorated or soldering I/O terminals may become difficult (some oxide is generated at I/O terminals plating).

1. Store as delivered by Optrex

2. If you store as unpacked, put in anti-static bag, seal its opening and store where it is not subjected to direct sunshine nor fluorescent lamp.

3. Store at temperature 0 to $+35^\circ\text{C}$ and at low humidity. Please refer to our specification sheets for storage temperature range and humidity condition.

Long-term Storage

Please use power supply with built-in surge protection circuit.

LCD MODULE SPECIFICATION FOR APPROVAL	DATE	31/05/05
	VER.	1.1
JHD529M1	PAGE	17

14. EXTERNAL DIMENSION

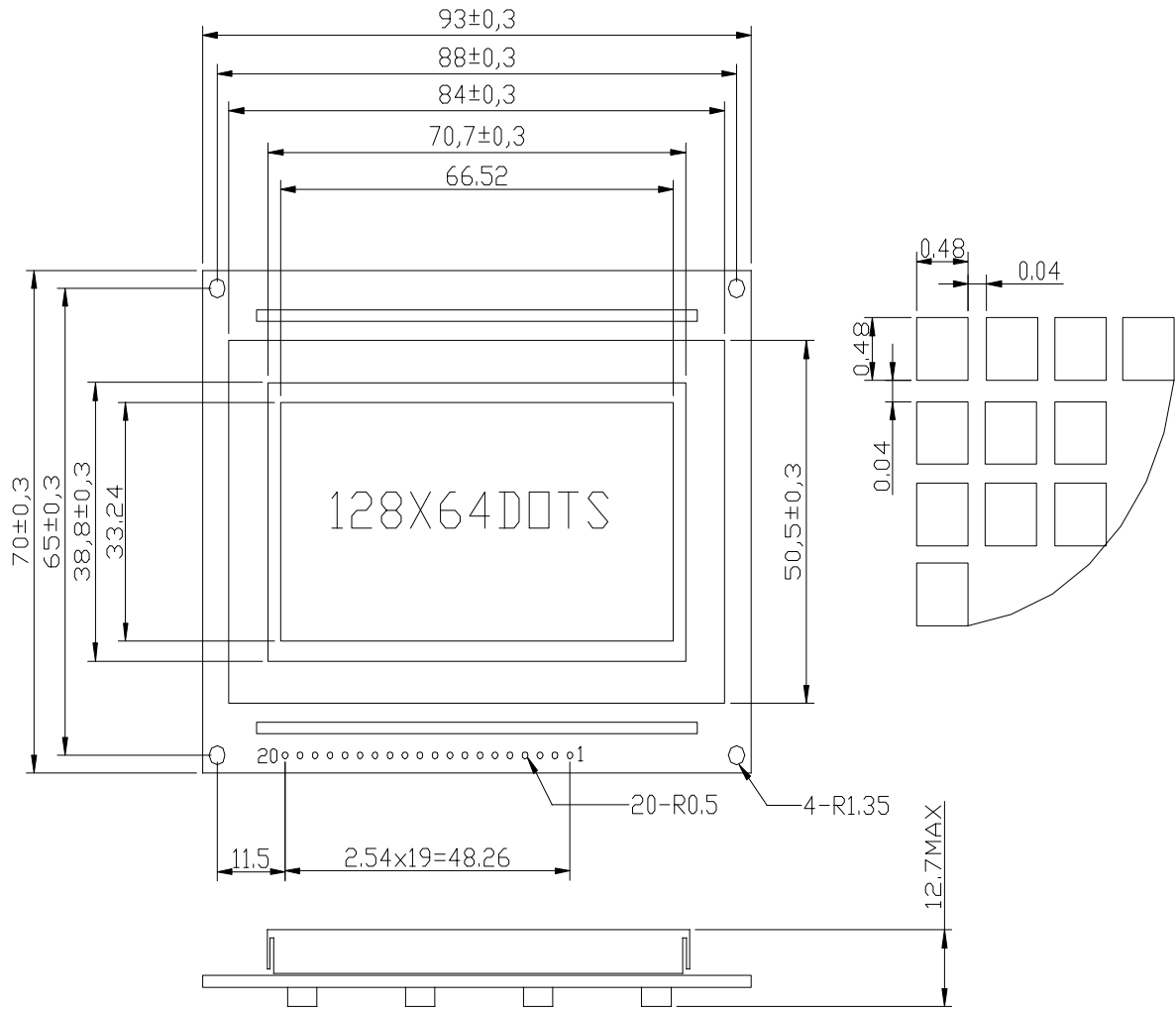



LCD MODULE SPECIFICATION FOR APPROVAL	DATE	31/05/05
	VER.	1.1
JHD529M1	PAGE	18

15. INTERFACE

PIN NO.	SYMBOL	DESCRIPTION	FUNCTION
1	VSS	GROUND	0V (GND)
2	VDD	POWER SUPPLY FOR LOGIC CIRCUIT	+5V
3	V0/VDD/NC	LCD CONTRAST ADJUSTMENT OR LCD VOLTAGE OR NC	
4	D/I	INSTRUCTION/DATA REGISTER SELECTION	D/I = 0 : INSTRUCTION REGISTER D/I = 1 : DATA REGISTER
5	R/W	READ/WRITE SELECTION	R/W = 0 : REGISTER WRITE R/W = 1 : REGISTER READ
6	E	ENABLE SIGNAL	
7	DB0	DATA INPUT/OUTPUT LINES	8 BIT: DB0-DB7
8	DB1		
9	DB2		
10	DB3		
11	DB4		
12	DB5		
13	DB6		
14	DB7		
15	PSB	SERIAL/PARALLEL SELECTION	PSB=0:SERIAL MODE PSB=1:8/4BIT PARALLEL BUS MODE
16	NC		
17	RST	RESET SIGNAL	RSTB=0,DISPLAY OFF,DISPLAY FROM LINE 0.
18	VEE/NC	LCD DRIVE VOLTAGE/NC	
19	A	SUPPLY VOLTAGE FOR LED+	+5V
20	K	SUPPLY VOLTAGE FOR LED-	0V